

8 DFCa technical data

| Type DFAa | Feed rate in ml/rev- olution | P max. in bar | Flow rate at max. pressure in l/h | Rollers/ shoes Shoes | Hose interior ø in mm | Solids max. ø in mm | Weight without drive in kg | Con- nector |
|--------------|------------------------------------|------------------|--|----------------------------|-----------------------------|---------------------------|-------------------------------------|----------------|
| 003 | 1,66 | 2 | 17,5 | Rollers | 3,2 | - | 2 | - |
| 008 | 10 | 2 | 105 | Rollers | 8 | - | 2 | - |

8.1 Dimensions DFAa 003/008

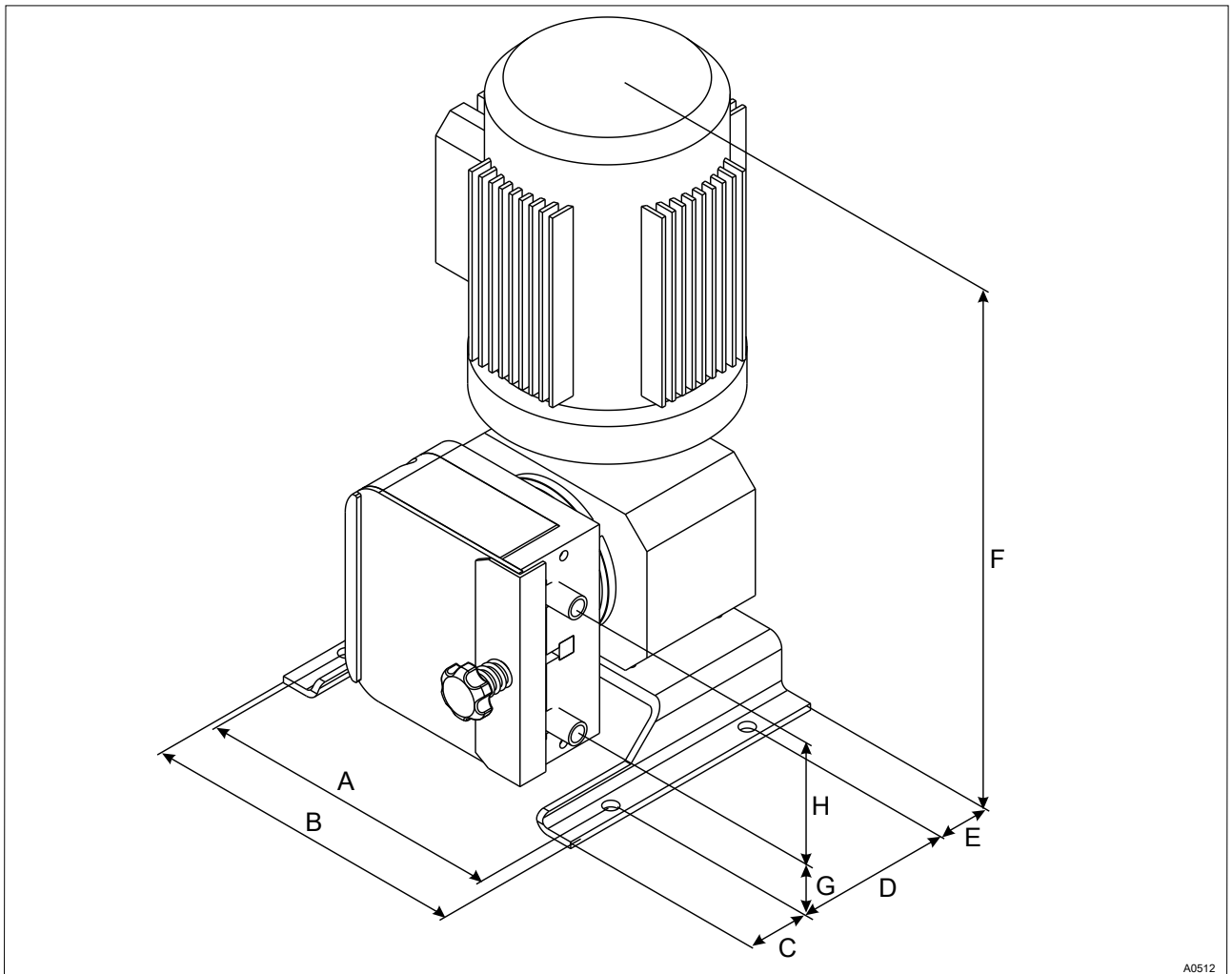



Fig. 4: Dimensions DFAa 003/008

A 180 mm
B 200 mm
C 36 mm
D 95 mm

E 36 mm
G 47 mm
H 76 mm

| Drive | Position "F" in mm |
|--------------|---------------------------|
| A10/B10 | 323 |
| A11/B11 | 323 |
| A12/B12 | 323 |
| A13/B13 | 325 |
| A14/B14 | 325 |
| A21/B21 | 439 |
| A22/B22 | 457 |
| A31/B31 | 355 |
| A41/B41 | 340 |

The drive version is specified by means of an Identcode, please refer to  *Chapter 1.3 "ID Code" on page 6*